

INSTALLATION INSTRUCTIONS

FCB SERIES CEILING MOUNT ELECTRIC HEAT DX COOL AIR HANDLER



IMPORTANT MESSAGE TO OWNER: These instructions should be carefully read and kept near product, for future reference. While these instructions are addressed primarily to the installer, useful maintenance information is included. Have your installing dealer acquaint you with the operating characteristics of the product and periodic homeowner maintenance requirements. As expressed in our product warranty, Aspen will not be billed for any structural damage due to failure to follow these installation requirements. Once installed, Aspen coils may contain chlorofluorocarbons (CFC's) or hydrochlorofluorocarbons (HCFC's). Under certain conditions, CFC's & HCFC's may pose a health risk. Please notify a licensed service technician immediately if you suspect your system may contain a leak.

IMPORTANT MESSAGE TO INSTALLER: The United States Environmental Protection Agency ("EPA") has issued various regulations regarding the introduction of disposal of refrigerants in this unit. Failure to follow these regulations may harm the environment and can lead to the imposition of substantial fines. Because these regulations may vary due to the passage of new laws we suggest that any work on this unit be done by a certified technician. Should you have any questions please contact the local office of EPA. Some Aspen coils may include a Schrader valve on the suction manifold. During installation, this Schrader valve must be protected from heat or it may leak. All Aspen coils are shipped with a nitrogen holding charge. DO NOT install the coil if this charge is not present.

CODES AND REGULATIONS

This product is designed and manufactured to permit installation in accordance with National Codes. It is the installer's responsibility to install the product in accordance with National Codes and/or prevailing local codes and regulations. The manufacturer assumes no responsibility for equipment installed in violation of any code or regulation.

INSPECTION

This product has been inspected and run tested at the factory and released to the transportation agency without known damage. Inspect exterior of carton for evidence of rough handling in shipment. Unpack carefully, if damage is found, report immediately to the transportation agency.

BLOWER DATA 1) Dry coil with filter in place 2) For 208v operation multiply by .90 (FCB series only)								
MODEL	MOTOR SPEED	MOTOR HP	MOTOR VOLTAGE	CFM VS. EXTERNAL STATIC PRESSURE (1,2)				
				0.10	0.20	0.30	0.40	0.50
FCBXX - 18	LOW	0.20	240	890	860	845	810	760
FCBXX - 24	HIGH	0.20	240	1020	990	975	939	892
FCBXX - 30	LOW	0.33	240	1116	1069	1010	960	899
FCBXX - 36	HIGH	0.33	240	1233	1178	1121	1054	984
FCBXX - 37	HIGH	0.33	240	1233	1178	1121	1054	984

REPLACEMENT PARTS

Order all replacement parts through your local distributor. When ordering parts, give complete model and serial number as shown on the unit rating plate.

INSTALLATION

PRODUCT LOCATION

AS EXPRESSED IN OUR PRODUCT WARRANTY, ASPEN WILL NOT BE BILLED FOR ANY STRUCTURAL DAMAGE DUE TO THE FAILURE TO FOLLOW THIS INSTALLATION REQUIREMENT.

The furnace is completely serviceable from the front. All Units are approved for 0" clearance.

This Electric Furnace allows substantial freedom in positioning the product to best serve the structure requirements. Units may, without field modification, be positioned for ceiling joist installation using the 1/2 inch offset mounting tabs or back mount installation using the back mounting tabs.. See page 3 for detailed installation instructions.

INSTALLATION CLEARANCES		
TOP	OPERATION	SERVICE
	0"	0"
FRONT	0"	30"
SIDES	0"	0"
REAR	0"	0"

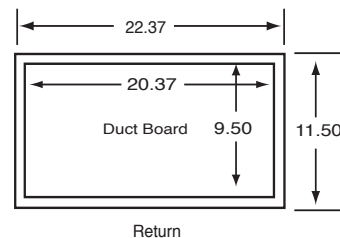
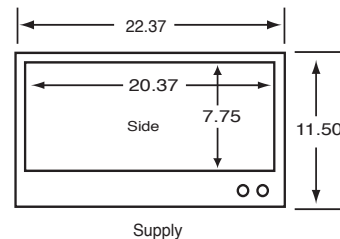
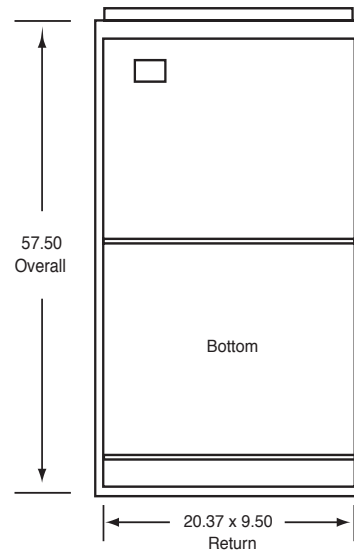

DUCT INSTALLATION

Air duct systems should be installed in accordance with standards for air-conditioning systems, National Fire Protection Association Pamphlet No. 90A or 90B. They should be sized in accordance with National Environmental System Contractors Association Manual K, or whichever is applicable.

On any job, non-flammable flexible collars should be used for the return air and discharge connections to prevent transmission of vibration. Although these units have been specially designed for quiet vibration-free operation, air ducts can act as sound boards and could, if poorly installed, amplify the slightest vibration to the annoyance level.

All main supply and return air drops should be run full size as determined by the designer of the duct system and should not necessarily be the size of the duct flange openings of the unit

When installing a central air return grille in or near the living space, it is advisable to design the ductwork so that the grille is not in direct line with the opening in the

unit. One or two elbows and acoustical duct liner will also assure a quieter installation and system.

It is recommended that wherever supply and return air sheet metal duct pass through unconditioned areas, they be insulated to prevent excessive heat loss during heating operation. When applied in conjunction with summer air conditioning, sheet metal duct routed through unconditioned areas should be insulated and have an outside vapor barrier to prevent formation of condensation.

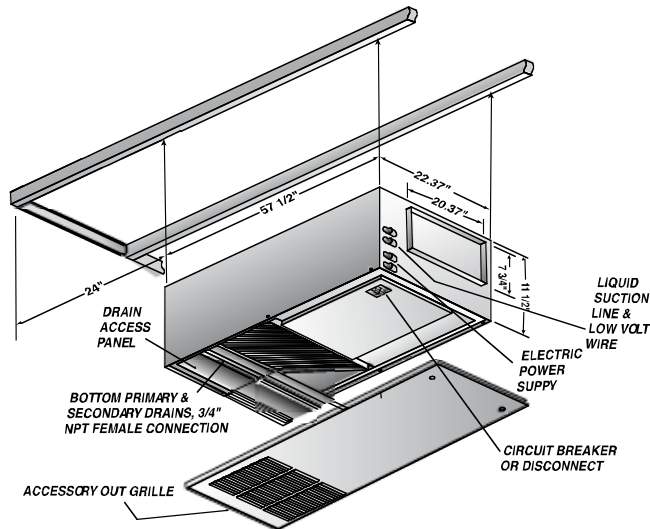

FIGURE 3 □

REFRIGERANT PIPING

Refrigerant piping should follow the recommended procedures set forth in the appropriate manual. Consideration should be given to routing refrigerant lines and condensate lines during installation so that there is no interference with service access.

INSULATION ON THE SUCTION LINE MUST EXTEND INTO CABINET AND CONTINUE AS FAR AS POSSIBLE TO ELIMINATE CONDENSATION FROM DRIPPING ON TO ACCESS DOOR.

LEFT HAND REFRIGERANT PIPING CONVERSION

- 1) Remove the bottom door.
- 2) Cut tie wrap and remove suction line insulation.
- 3) Re-install suction line insulation on right hand stubout and tie wrap.
- 4) Replace right hand cabinet bushings with left hand bushings and vice versa.
- 5) Cut suction line tube and braze line inside cabinet.
- 6) Bend a 180-degree elbow on liquid line stubout.
- 7) Run liquid line inside cabinet.
- 8) Braze liquid line inside cabinet.
- 9) Be sure the suction line insulation extends into cabinet and past drain pan as far as possible. Failure to adhere to this requirement will result in condensate dripping onto ceiling or access door.

CONDENSATE PIPING

Any refrigerant coil used requires condensate connections. An auxiliary drain pan must be installed

on installations where condensate overflow may cause damage. ALL CONDENSATE LINES (PRIMARY AND SECONDARY) MUST BE TRAPPED SINCE COIL CAVITY IS UPSTREAM OF THE BLOWER.

ELECTRICAL INSTALLATION

These units are designed for single-phase 208/230 Volt 60 Hertz power supply for FCB series and 120 Volt 60 Hertz power for the FCD series. Wire selection and wiring must be in accordance with the National Electric Code and/or local codes. Unit terminals are designed to accommodate copper and aluminum wiring. If aluminum wiring is used, please observe the special precautions relative to sizing, handling, wire connections and corrosion protection.

All models with electric heat are arranged for single circuit connection.

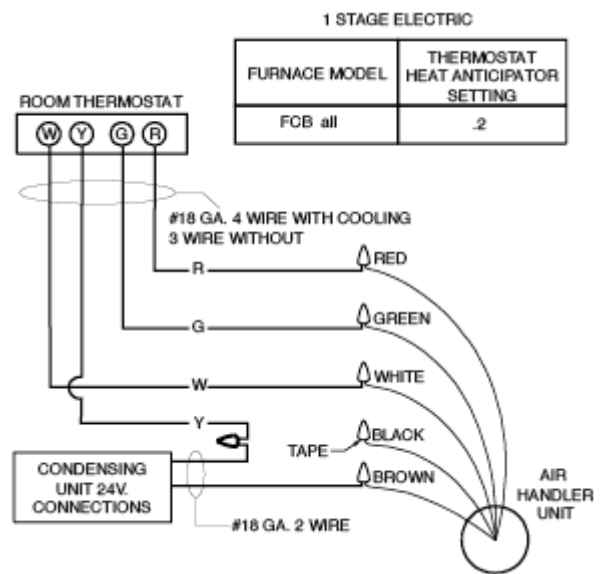

START UP

After all connections are made, start up and check out of the unit must be performed before proper evaluation of the entire system can be made. Make sure that heat anticipator is properly set as noted on low voltage wiring diagrams.

Load requirements can vary in each residence and it may be necessary for the installer or homeowner to make slight adjustments to the heat anticipator setting for longer or shorter cycles. It is recommended to change the setting no more than plus or minus .05 amp. at one time. Greater changes can cause the unit to rapid cycle or remain on excessively. To properly check the unit's operation, the installer should have an electrical current measuring device (0-10 amp Amprobe), air pressure measuring device (0-1.0 in slope gauge), and a temperature-measuring device (0-200°F thermometer). Install the amprobe to measure blower current, the slope gauge to measure static air pressure at the units and the temperature device to measure unit supply and return air temperature. Before taking measurements, be sure that all registers, grilles and dampers are open or are set to their proper positions. Be sure that clean filters are in place.

Temperature measuring device must be installed to obtain average temperature at both inlet and outlet. For outlet, measure temperature of each main trunk at a location far enough away to avoid heater radiation and read the average temperatures.

ELECTRIC FURNACE (FCB series only)

1. Turn on power supply. Set thermostat fan switch to on. Set the cooling indicator to maximum, heating to minimum. System switch may be on heat or cool. Check slope gauge measurement against appropriate air flow chart. Make damper, register and motor speed adjustments to obtain required airflow.
2. Set thermostat fan switch to auto, system to heat and thermostat heating indicator to maximum heat. Blower should start and all heat be energized.
3. Check air flow using temperature rise method.

$$\text{CFM} = \frac{\text{OUTPUT (BTUH)}}{1.08 \times \text{TEMP RISE}}$$

NOTE: BTUH output should be computed by VOLT x AMPS x 3.4 = BTUH OUTPUT. Since line volt can vary, do not use nameplate rating to determine output.

OPERATION AND MAINTENANCE

1) Room Thermostat- This is the device that controls that operation of your heating and/or cooling unit. It senses the indoor temperature and signals the equipment to start or stop maintaining the temperature you have selected for your comfort. The room thermostat should be in a central, draft free inside wall location for best operation. Do not place any heat producing apparatus such as lights, radio, etc., near the thermostat as this will cause erratic operation of the comfort system. The thermostat can accumulate dust or lint, which can affect its accuracy. It should be cleaned annually.

2) Air Filter(s)- All central air moving comfort systems must include air filter(s). These filters will be located either in the equipment or in the return air duct system upstream of the equipment. The filter(s) removes dust and debris from the air thus helping to keep your air-conditioned space clean. More important, the filter keeps dust and debris from collecting on the heat transfer surfaces thus maintaining optimum equipment efficiency and performance. Inspect and clean or replace filters every month. This routine maintenance procedure will pay big dividends in reduced operating cost and reduced service expense. Never operate comfort equipment without filter(s).

3) Fuses and/or Circuit Breakers- This comfort equipment should be connected to the building electric service in accordance with local and National Electric codes. This electrical connection will include over current protection in the form of circuit breakers. Have your contractor identify the circuits and the location of over current protection so that you may be in a position

to make inspections or replacements in the event the equipment fails to operate.

4) WARNING: Failure to adhere to these warnings may result in serious injury or death.

- A) Do not store combustible materials or use gasoline or other flammable liquids or vapors in the vicinity of this appliance.
- B) Do not operate the comfort equipment with panels removed. Operation may result in hazardous fumes and/or vapors entering the conditioned space.
- C) Have your contractor point out and identify the various cut-off devices, switches, etc., that serve your comfort equipment. There is a main switch that will cut off energy to your heating system. Know where they are so that you may cut off the flow of energy in the event of overheating.

5) Periodic Checkup and Service- This product is designed to provide many years of dependable, trouble-free comfort when properly maintained. Proper maintenance will consist of annual check-ups and cleaning of the internal electrical and heat transfer components by a qualified service technician. Failure to provide periodic checkup and cleaning can result in excessive operating cost and/or equipment malfunction.

6) Lubrication- Direct drive blower motors are equipped with permanently lubricated bearings and do not require further lubrication.